

T 815-7ZOR9T 44 440 8x8.1R



8x8 HMHD RECOVERY VEHICLE

The High Mobility Heavy Duty Recovery Vehicle is able to recover armoured vehicles very quickly and efficiently in a tactical environment. The vehicle capability and payload enabling to recover heavy armoured vehicles and it is capable of towing most types of current and future wheeled vehicle systems and their variants. The vehicle is able to overturn crashed vehicles, perform slope recovery and make an access to unapproachable places.

This vehicle can be also engaged into a high mobility recovery trailer for evacuation of completely immobilized vehicles. Rear lifting fork is controlled either from a fixed control panel or by the wireless remote control from. The recovery vehicle is able to tow vehicles, with front axle load up to 14,000 kg.

The recovery vehicle is equipped by 44 Tm Hiab crane with a remote control. The crane operator can be positioned at the best possible location when operating the crane. The crane provides the most advanced control system on the truck-crane market today, delivering unrivalled speed, precision and safety, which maximize productivity by ensuring super-smooth operation in an instant.

The recovery vehicle is equipped by two main winches with constant pull 24 t, 100 m rope, and 2-ton additional winch with 220 m rope. Front dozer blade is removable and it can be used for engineering work like digging of trenches, making roads and removing obstacles or barriers. All-wheel drive. ADM (Automatic Drivetrain Management), a fully automatic differential lock operating system for managing locks. CTIS operated on the fly. Armoured cab in Level 2, STANAG 4569 - ballistic add-on armouring and anti-mined floor.

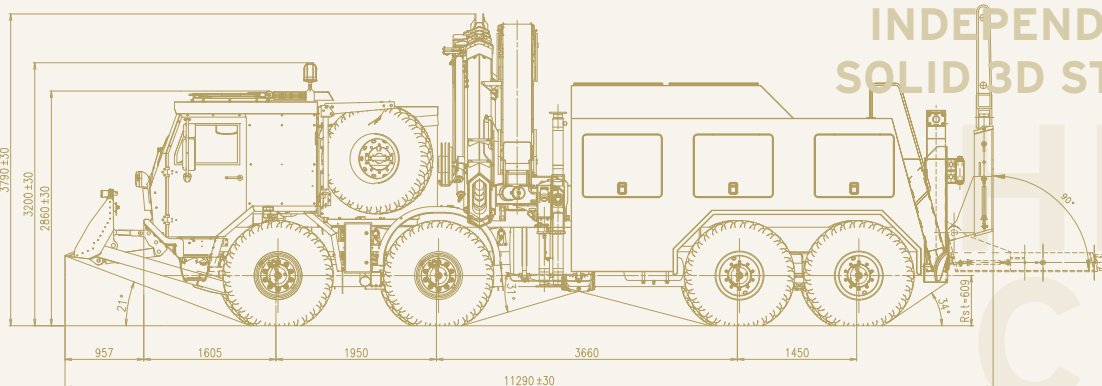

INDEPENDENT SUSPENSION
SOLID 3D STRUCTURE FRAME
43,900 tm CRANE
8x8 DRIVE
440 kW

TATRA IS THE SOLUTION



T 815-7

T 815-7ZOR9T 44 440 8x8.1R

8x8 HMHD RECOVERY VEHICLE

ENGINE

Water cooled, four stroke turbo-charged and charge-air-cooled direct injection Diesel.

Model	DEUTZ TCD 2015 V08
Number of cylinders	8V
Bore/stroke	132/145 mm
Displacement	15.9 ltrs
Power output	440 kW/2,100 RPM
Max. torque	2,720 Nm/1,400 RPM

TRANSMISSION - Allison 4800SP

Automatic, no. of gears forward/reverse	7/1
Hydraulic retarder integrated.	

TRANSFER BOX

Type TATRA 2.30 TRK 1/1.6. Speed reducing.
Pneumatic control.

FRONT AXLES

TATRA steered and driven swing half-axles with independent wheel suspension, axle differential locks and inter-axle differential lock.
Wheel hub reductions.
Air springs and telescopic shock absorbers, swing bars.

REAR AXLES

TATRA driven swing half-axles with independent wheel suspension, axle differential locks and inter-axle differential lock. Wheel hub reductions.
Combined suspension.

STEERING

Left/right hand drive, integral power steering.

BRAKES

Wedge type self-adjustable drum brake units, ABS.
Four separate brake systems: service, emergency, parking, and engine brake.

WHEELS

Single tactical tyres on all axles with CTIS.	
Rims	20 -10.00V
Tyres	16.00 R20
Run-flats	

CAB

COE type, medium size, forward tilting, all-steel, two doors, driver's adjustable seat with safety belt, firm 4 seats with safety belt, flat 2-piece windscreen, right-left design, roof manhole. Rifle racks, sun visors, HVAC unit. C-130 transportable. Add-on armouring - Level 2 STANAG 4569 (ballistic and antimined).

ELECTRIC EQUIPMENT

Nominal voltage	24 V
Batteries	4x12V, 240 Ah
Alternator	120 A/28 V

DIMENSIONS

Width	2,500 mm
Track - front/rear	2,074/2,018 mm
Clearance	390 mm
Clearance can be temporarily raised/lowered by suspension on the fly.	

WEIGHTS

Curb weight (w/ armoured cab)	35,000 kg
Fork load from suspended towing max.	14,000 kg

PERFORMANCE

Top speed	100 km/h
Gradeability at GVW (calculated)	> 100 %
Side slope	45 %
Turning circle diameter (curb to curb)	27 ± 1 m
Fording capability	1,200 mm
Crossing ability - trench width	2,100 mm
Climbing ability - vertical step	600 mm
Fuel tank	2x320 ltrs
Cruising range (on road)	700 km
Operating ambient temperature	-32°C to +49°C

EQUIPMENT

Crane - capacity 43.9 Tm, outreach 8.4 m, outreach lifting capacity 5,200 kg/8.4 m to 12,000 kg/3.5 m, remote control.
2 main winches 2x24 t (constant pull), rope 100 m. Additional winch 2 t, rope 220 m.
Dozer blade.
Rear fork with capacity 14,000 kg.
CTIS - automatic.
Trailer hook - automatic, incl. electric and braking system coupling.



TATRA EXPORT s.r.o.

Areál Tatra 1450/1, 742 21 Kopřivnice, Czech Republic
tel.: +420 556 492 398, fax: +420 556 492 672, e-mail: defence@tatra.cz

tatra.cz